

**Flexible.  
Precise.  
Unique.**

**HC HOMAG**

**Our edge banding machines**

EDGETEQ S-340 (NKR 782)

**YOUR SOLUTION**

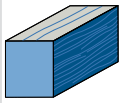
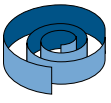
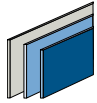
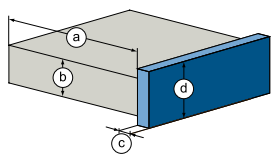

	SOLID (mm)	COILS (mm)	STRIPS (mm)
			
<b>a</b>	with b = 22: min. 70 with b = 40: min. 125		
<b>b</b>	8 – 60		
<b>c</b>	0,4 – 8mm	0,4 – 3,0	0,4 – 3,0
<b>d</b>	65		
			

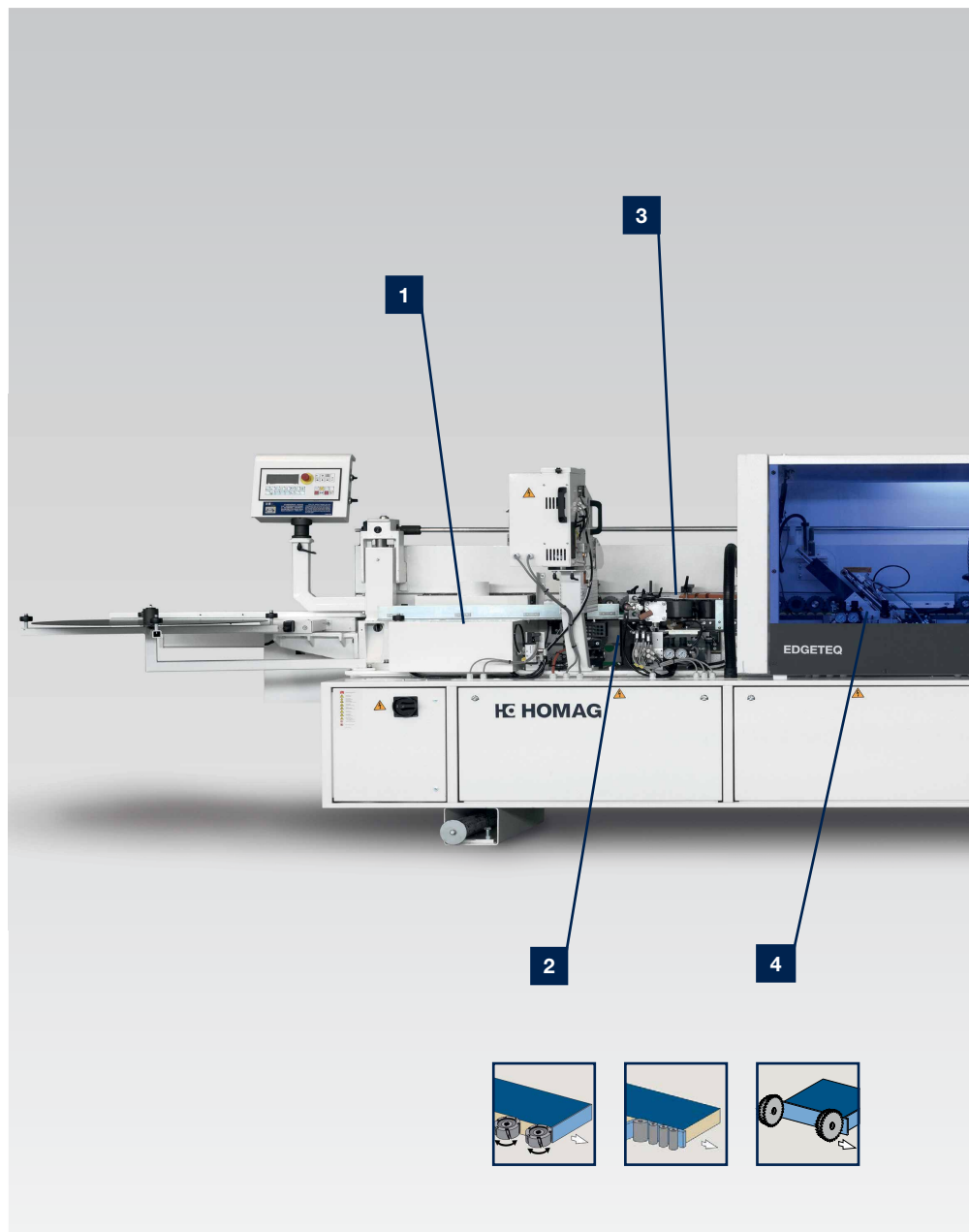

## EDGETEQ S-340 - Sets new standards in performance and quality

The EDGETEQ S-340 offers complete processing due to its comprehensive equipment. The powerful motors on all units provide the unrestricted power which is needed to process a broad spectrum of different parts.

Whereas the joint trimming unit guarantees the ideal formatting of the panel, the Quick Melt gluing unit guarantees the optimal edge banding. The snipping unit is equipped with 2 motors and offers a highly precise cut. High performance of rough trimming and fine trimming units are rounding off the picture. The 2-motor profile trimming unit in the EDGETEQ

S-340 machines enjoy all the advantages of an entire processing, being supported by the radius scraping unit, the glue joint scraping unit and the buffing unit, making the finish absolutely perfect. The feed speed of 20 m/min and workpiece gap are bringing out the ultimate effectiveness of this series.

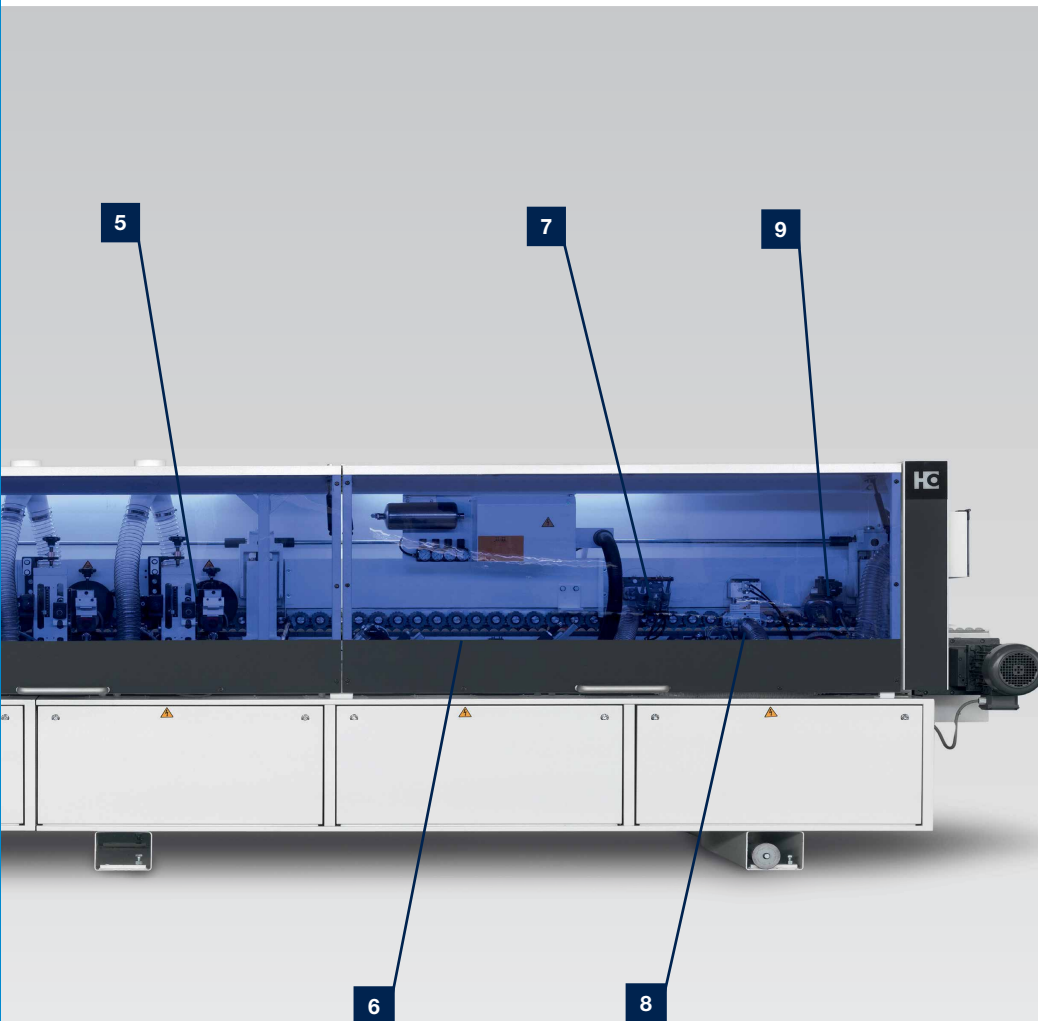

**EDGETEQ S-340**

- 1** Joint trimming unit
- 2** Gluing unit
- 3** Pressure zone
- 4** Snipping unit
- 5** Trimming units
- 6** Profile trimming unit
- 7** Profile scraping unit
- 8** Glue joint scraping unit
- 9** Buffing unit

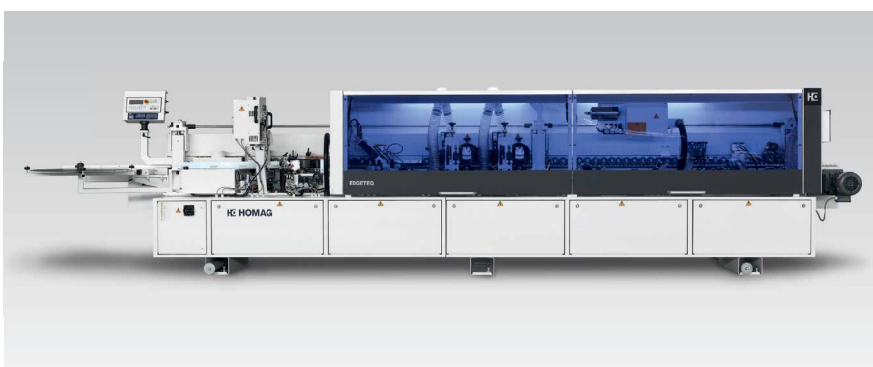
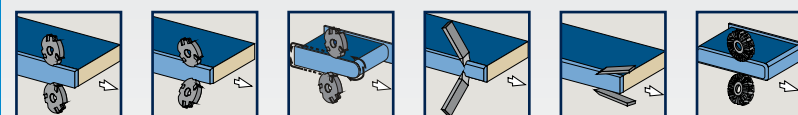

**MATERIAL TYPES**

- 0.4 mm melamine
- 2 mm ABS
- Veneer (coil)
- 8 mm solid wood strip



## The controller – Quality and precision with the touch of a button

Through targeted and constant development of controller technology, simple operation and a high operating comfort

are guaranteed. At HOMAG we focus on you as our customer and your finished product.

### BENEFITS

easyControl EC 10+, offering every “plus” for the customer

- High operating convenience through simple menu format and optimized linepoint adjustment
- Fast access to all unit functions through dedicated control buttons
- Quick change over to different edge banding material through user-defined programs
- Easy to read large 4-line operating display
- Clear text error diagnostics provide high operating convenience



**Spraying unit (Optional)**

Spraying agents for optimal processing results, even for sensitive surfaces.

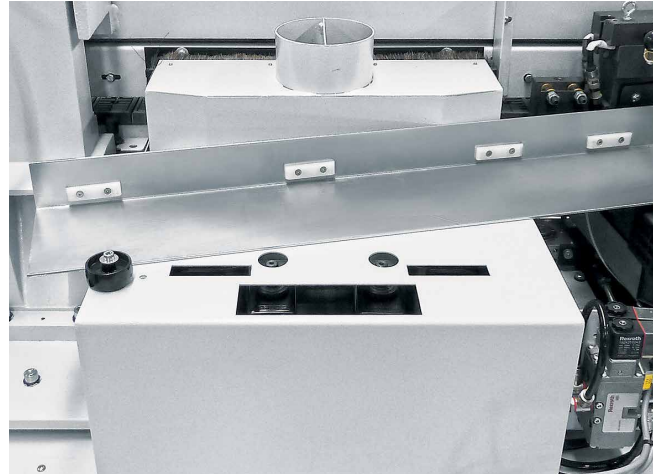
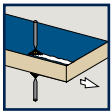

**Joint trimming unit**

Perfect cut and long service life due to diamond tipped tools for optimum edge joint quality.

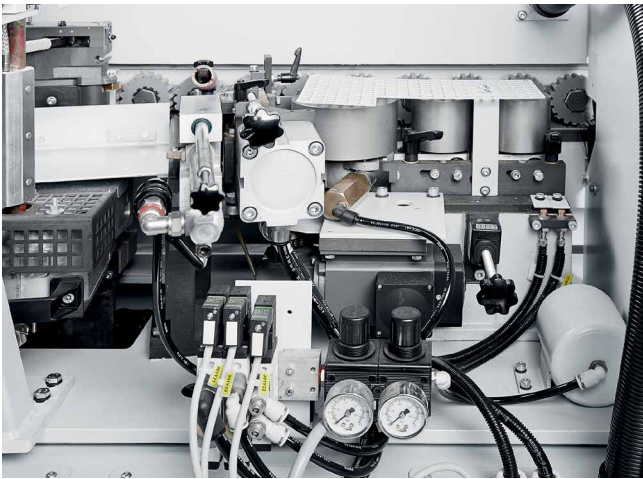
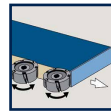

**Gluing unit**

Quick-change application unit with hot melt glue supply from beneath.

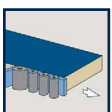

**YOUR BENEFITS AT A GLANCE**

- Optimum glue application on the narrow surface
- Changes to workpiece thicknesses do not necessitate resetting of the glue application roller
- Glue roller with integrated heating guarantees constant temperature and viscosity for all workpiece thicknesses
- Tracing pad prevents wear of the application roller and ensures a consistent glue film thickness
- Easy removal of the application unit

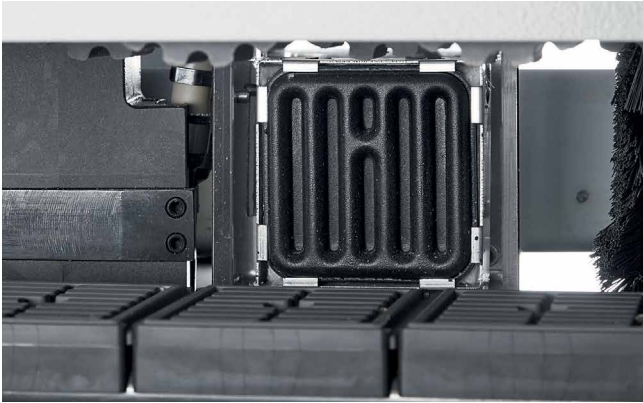

**Radiant heater**

Strong adhesion through optimal pre heating of the workpiece.



**Pre-melter**

On-demand availability and perfect glue quality with Quickmelt.

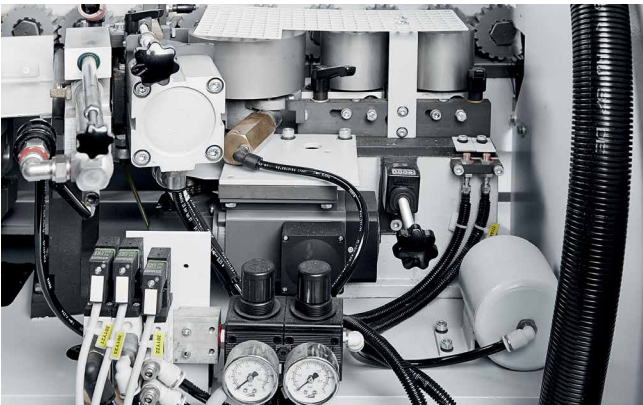

**Pressure zone**

Heavy pressure zone up to 8 mm edge thickness and 60 mm workpiece height for an optimal glue joint.

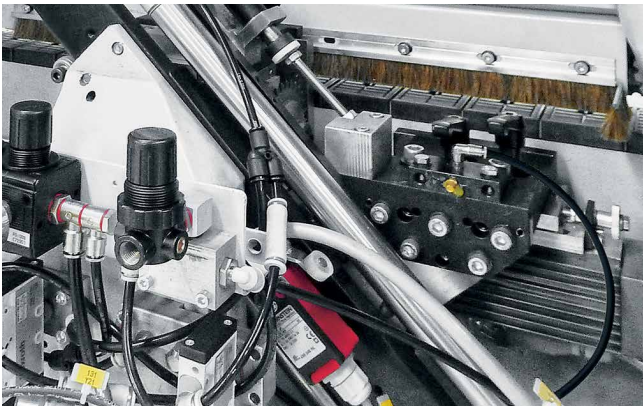

**Snipping unit**

Precise end-cut through a strong snipping unit, equipped with high-precision linear guides, incl. soft touch. Gap 550 mm, max. feed speed 20 m/min.

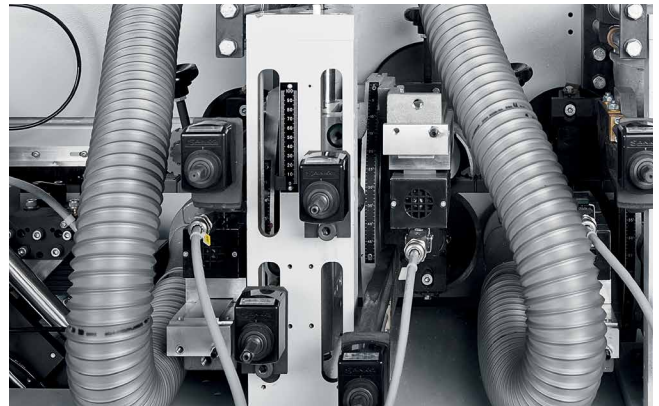
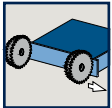

**Trimming unit**

Flexible adaptation for different edge thicknesses.

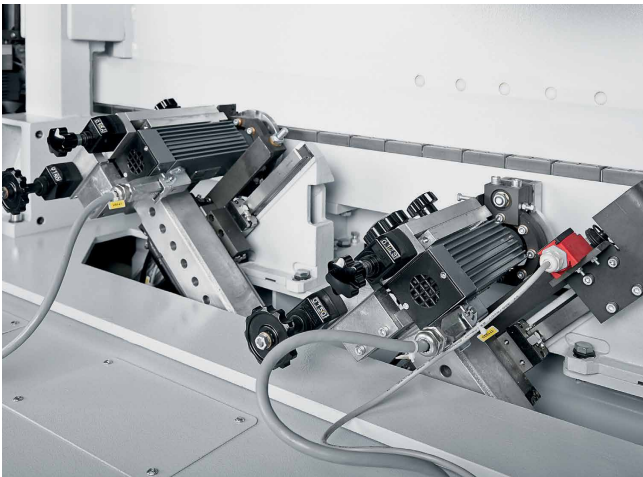
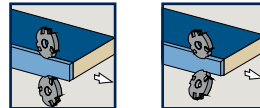

**Profile trimming unit**

For profile trimming of thick PVC edges, as well as postforming and soft forming profiles. Workpiece thickness up to 60 mm. Max. feed speed 16 m/min.

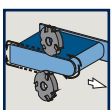

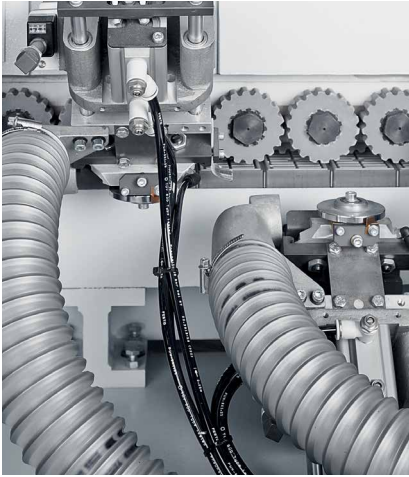

**Profile scraping unit**

To smooth radii. Standard pneumatic on/off. For easy operating, e.g. 0.4 mm and 1,5 mm.

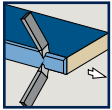

**Glue joint scraping unit**

For the perfect finish. Standard pneumatic on/off. For easy operating.

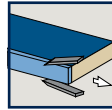

**Buffing unit**

Buffing unit to polish edges and maintain their natural colour.

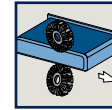



**TECHNICAL DATA NKR 782**

MACHINE DIMENSIONS		EDGETEQ S-340
Machine length (mm)		7,180
Working height (mm)		900
WORKING DIMENSIONS		
Workpiece thickness (mm)		8 – 60
Edge material thickness (mm)		0.4 – 8 mm
MISCELLANEOUS		
Feed speed (m/min)		20 / 16
Weight (kg)		2,750
Pneumatics (bar)		6
Electrics		for all supply networks worldwide

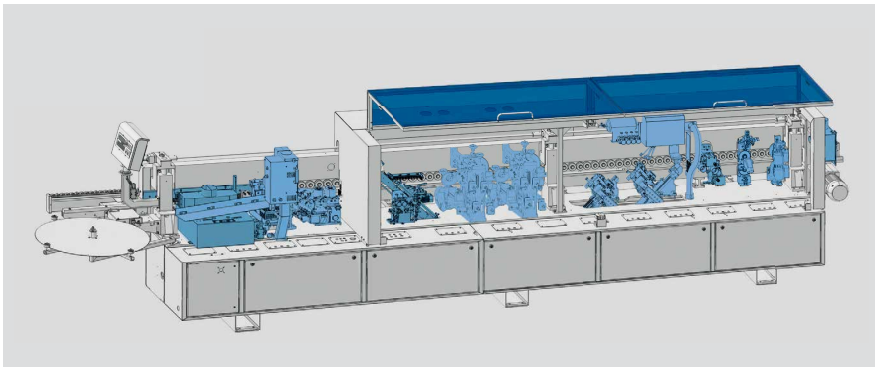

**EDGETEQ S-340**



## HOMAG Life Cycle Services

The sale of our machines comes with all-in optimum service backup and individual advice. We support you with service innovations and products which are specially tailored to your requirements.

With short response times and fast customer solutions we guarantee consistently high availability and economical production - over the entire life cycle of your machine.



### Remote Service

- Hotline Support by remote service for control systems, mechanics and process technology, resulting in >90% fewer on-site servicing callouts
- Mobile applications such as ServiceBoard reduce costs due to rapid assistance in case of faults using mobile live video diagnostics and the online spare parts shop eParts



### Spare Part Service

- Round-the-clock identification, inquiries and direct ordering of spare parts at [www.eParts.de](http://www.eParts.de)
- Local availability of parts through sales and service companies, as well as sales and service partners all over the world
- Reduced downtimes due to defined spare part and wearing part kits



### Modernization

- Keep your machinery up to date and increase your productivity and product quality to prepare yourself today for the product requirements of tomorrow
- We provide support in the form of upgrades, modernization, individual advice and development

**1,200**  
 service employees around the world

**>90%**  
 less on-site-services through successful remote diagnosis

**5,000**  
 customer training sessions per year

**>150,000**  
 machines electronically documented in 28 languages in eParts



**Training**

- Training tailored precisely to your requirements ensures the optimum operation and maintainance of your HOMAG machinery by your own machine operators
- Courses include customer-specific training documentation complete with practical training exercises

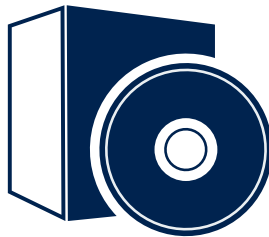

**Software**

- Telephone assistance and advice by Software Support
- Digitalization of your samples by means of 3D scanners saves time and money compared to new programming
- Subsequent networking of your machine outfit using smart software solutions from design through to production



**Field service**

- Increase of machine availability and product quality by certified service staff
- Assurance of the highest quality of your products by regular checks through maintenance / inspection
- Minimized downtimes due to unpredictable faults due to the ready availability of qualified technicians

## **HOMAG Group AG**

info@homag.com

www.homag.com



## **YOUR SOLUTION**