

DRILLTEQ

H-230 | H-330

Single-channel and double-channel models -
6-sided Processing Center Family







DRILLTEQ H-230 DRILLTEQ H-330

The 6-side drilling series DRILLTEQ H-230/330 impress with speed and precision - in workpiece handling as well as in machining. Every drilling and milling operation is set with extreme repeat accuracy. The workpiece surfaces are perfectly protected despite fast processing speeds.

The possibility of processing two workpieces at the same time results in double efficiency and the versatile connection options of the machine bring high flexibility.

With our single-channel and double channel 6-sided drilling series, we provide the perfect solution for your wishes and requirements.

www.homag.com

CONTENTS

- 04 Networked worldwide
- 06 Quality
- 08 6-sided-processing technology
- 10 6-sided-processing at its best
- 12 Optional equipment
- 14 Drilling
- 16 Tool change system
- 17 HSK interface
- 18 Comprehensive safety concept
- 20 Discover the connectivity options
- 24 powerTouch
- 26 Software
- 27 HOMAG China
- 28 Life Cycle Services
- 30 Technical data

Networked worldwide – HOMAG is always at your side

INDIVIDUAL CUSTOMER WISHES, DEMANDING PRODUCTS AND A WIDE VARIETY OF MATERIALS – the needs of your customers are constantly growing. And this means that the challenges for you and your production grow too. Our aim is to offer you the solutions you need to

accommodate the desire for individuality. To produce flexibly and efficiently and set trends in the industry. We support wood processing businesses of any size on their way to the top. With machines and technologies that grow with you – including the right software solutions and service.



German Headquarter in Schopfloch



Everything from a single source.

HOMAG meets all the requirements and wishes for the machines you have today. Handling systems, panel dividing technology, format and edge processing, drilling systems, sanding technology, spray coating and laminating technology, automation systems and software form a complete and innovative range of products and services. You benefit from a high degree of precision, performance and the right technology to ensure absolute flexibility, which you can use to optimize your entire production capacity.



Perfection can be programmed.

The software solutions from HOMAG optimize processes in small and medium-sized enterprises and global industrial manufacturers of furniture. From the first sketch to the final product – our software solutions are perfectly adapted to HOMAG machines. They create efficiency and reliability in the order and production process.



HOMAG Life Cycle Services

The sale of our machines comes with all-in optimum service backup and individual advice. We support you with service innovations and products which are especially tailored to your requirements. With short response times and fast customer solutions we guarantee consistently high availability and economical production – over the entire life cycle of your machine.



HOMAG a global player
Production, sales and service network

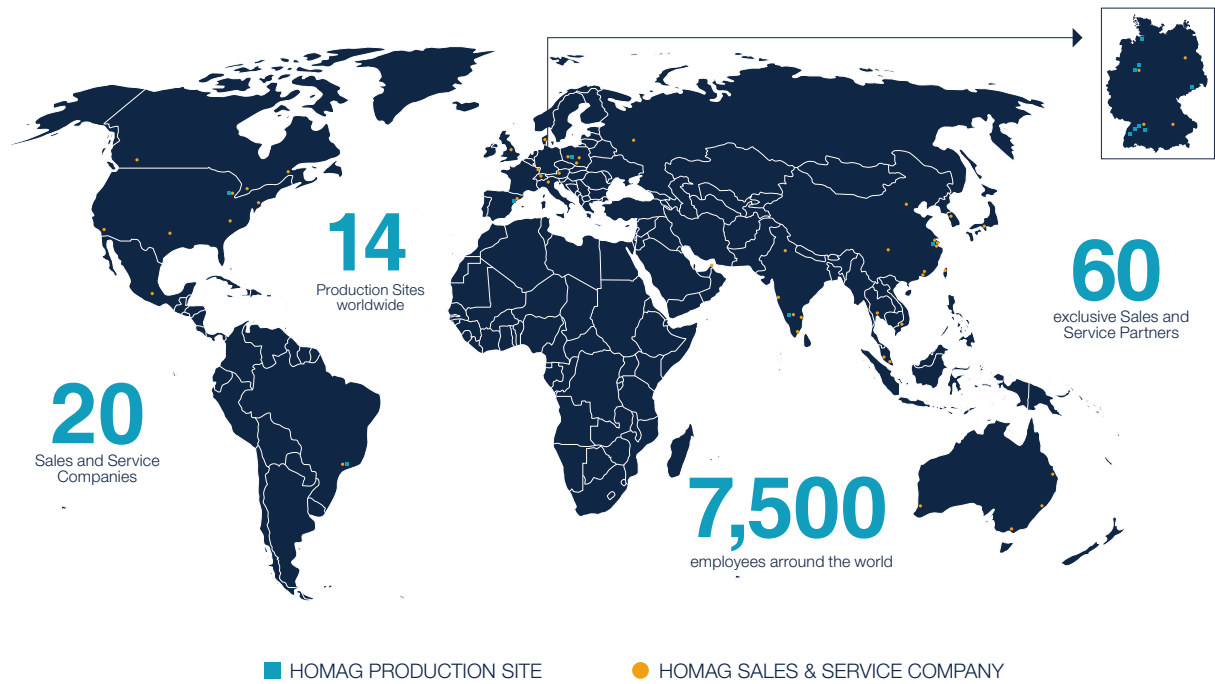

International and expert. With sales partners in over 100 countries, HOMAG has a global presence and is able to offer you a strong partnership. We make your company competitive and your business success long-lasting.





Proven technologies developed in Germany have naturally been applied to this machine series. We as HOMAG Group stand for high quality and technical availability of this model series. Your customers will feel the added value.

Werner Brinkhaus
Director Product Management CNC Processing



**We stand
for the quality...**

HC | HOMAG



German standards make working with this machine very comfortable and additionally safe in operation. Standard safety features such as fences or covers are installed to protect everybody involved, because they are important to us!

Xuesong Liu
Product Development Manager



...with our name!



Our goal is to support our customers by offering high-level products made in China with German Quality. "DNA from Germany" is our motivation and commitment. We associate this quality sealing with customers' voice.

Aaron Zhang
Product Manager

DRILLTEQ H-230 – The perfect start in the 6-sides-processing technology

Operation with one working field for precise drilling process at panels in all 6 sides.
High-speed drilling spindles and routers are available.
With optional tool change spindle, more application can be realized on this machine in order for high-level flexibility.

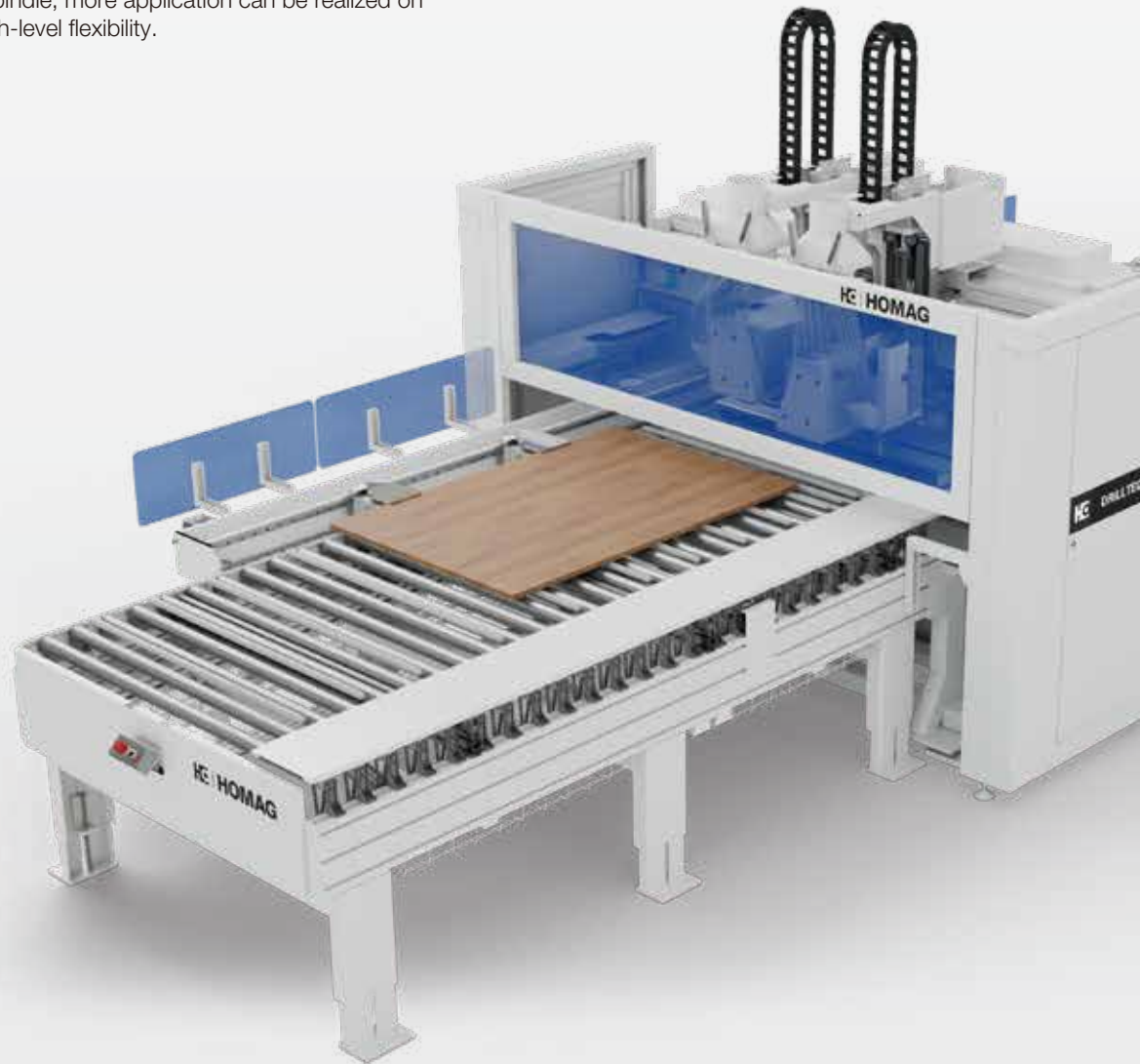

CNC-controlled clamping system

- Quick and precise- no setting times
- Workpiece thickness up to 40 mm



High Speed Processing Unit | Top Head | HighSpeed 7500

- One Drilling Block V13, H6X, H6Y, Optional router
- Two Drilling Block V13, H6X, H6Y, Optional router



FULL PANEL PROCESSING...

Routing and Drilling units perform in highspeed. 6 sided-processing along 1 working field

EVERYTHING UNDER CONTROL...

2 CNC-controlled clamping devices ensure permanently firm and precise positioning of the workpieces – regardless of the speed

EASY HANDLING...

Even workpiece dimensions of Length 250-3000 and width 60(40)-1250 mm are easy to handle

PRECISE IN DEPTH...

The spindle clamping technology ensures an always accurate drilling depth for all drilling

CONSTANTLY AT TOP LEVEL...

The closed straight guiding system is protected against dust and dirt and thus very durable

MORE PROCESSING POSSIBILITIES...

Optional top electric spindles with automatic tool changer make processing more possibilities.

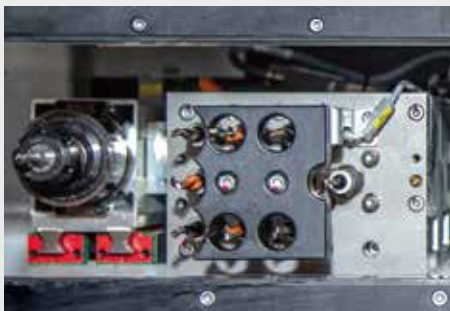

High Speed Processing Unit | Bottom

- One Drilling Block V8, router 3.5kW



Tool Change System (Option)

- Electric Spindle with HSK F63
- 4-fold linear tool changers installed at machine side

DRILLTEQ H-330 – 6-sided-processing at its best

By feeding two work fields at the same time, the DRILLTEQ H-330 offers virtually two machines in one. While production is running on one work field, the workpiece can already be prepared for seamless further processing on the second. This guarantees high availability and highly flexible production.



CNC-controlled clamping system on both sides

- Quick and precise – no setting times
- Workpiece thickness up to 40 mm



High Speed Processing Unit | Top Head | HighSpeed 7500

- Left side V13, H6X, H6Y, Optional router 3.5KW or 4.5KW
- Right side V13, H6X, H6Y, Optional router 3.5KW or 4.5KW

powerTouch 2



FULL PANEL PROCESSING...

Routing and Drilling units perform in highspeed. 6 sided-processing along 2 working fields

EVERYTHING UNDER CONTROL...

4 CNC-controlled clamping devices ensure permanently firm and precise positioning of the workpieces – regardless of the speed

EASY HANDLING...

Even workpiece dimensions of Length 250-3000 and width 60(40)-1250 mm (2 x 620 mm) are easy to handle

PRECISE IN DEPTH...

The spindle clamping technology ensures an always accurate drilling depth for all drilling

CONSTANTLY AT TOP LEVEL...

The closed straight guiding system is protected against dust and dirt and thus very durable

MORE PROCESSING POSSIBILITIES...

Optional top electric spindles with automatic tool changer make processing more possibilities.



High Speed Processing Unit | Bottom

- Left side V8, Optional router 3.5KW
- Right side V8, Optional router 3.5KW

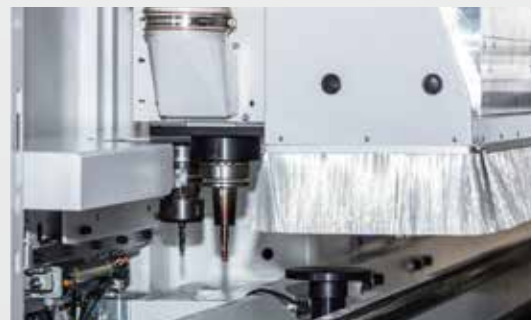

Tool Change System (Option)

- Electric Spindle with HSK F63
- 4-fold linear tool changers installed at machine sides

DRILLTEQ H-230 – Single-channel operation



Classic Package - infeed and outfeed by labour

- Processing can be launched by scanning the bar code
- High flexibility due to manual operation
- In-feed with air-cushion table and out-feed with support table or cross belt

Premium Package - Automate your processes

- Each workpiece is concretely identified for further part flow by means of barcode
- High batch processing
- In-feed and out-feed with roller conveyors and the necessary hardware
- Interface for Link to HOMAG simple automation

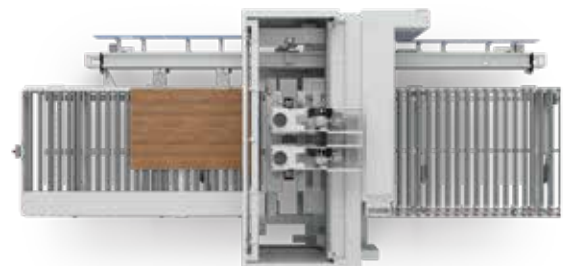

DRILLTEQ H-330 – Double-channel operation



Classic Package- double labour efficiency

- Processing can be launched by scanning the bar code
- Basis for faster part flow with higher process quality
- In-feed with air-cushion table and out-feed with support table

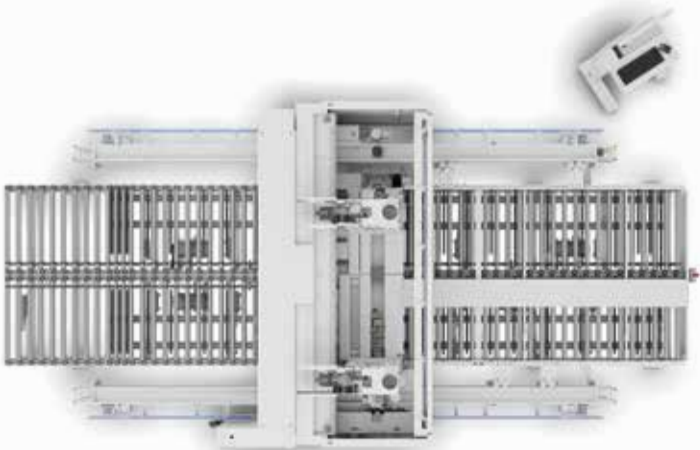
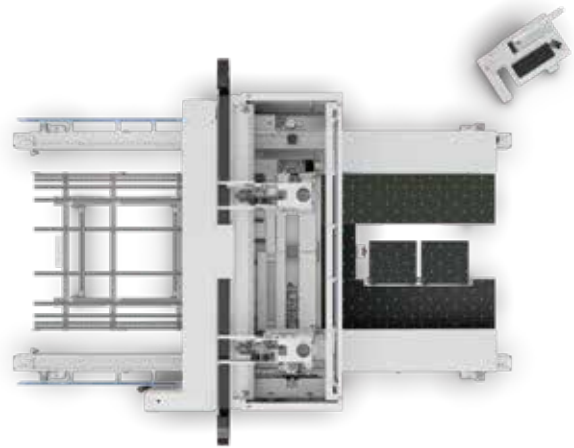

Premium Package - Automate your processes

- Each workpiece is concretely identified for further part flow by means of barcode
- Basis for faster part flow with higher process quality
- In-feed and out-feed with roller conveyors and the necessary hardware
- Interface for Link to HOMAG simple automation

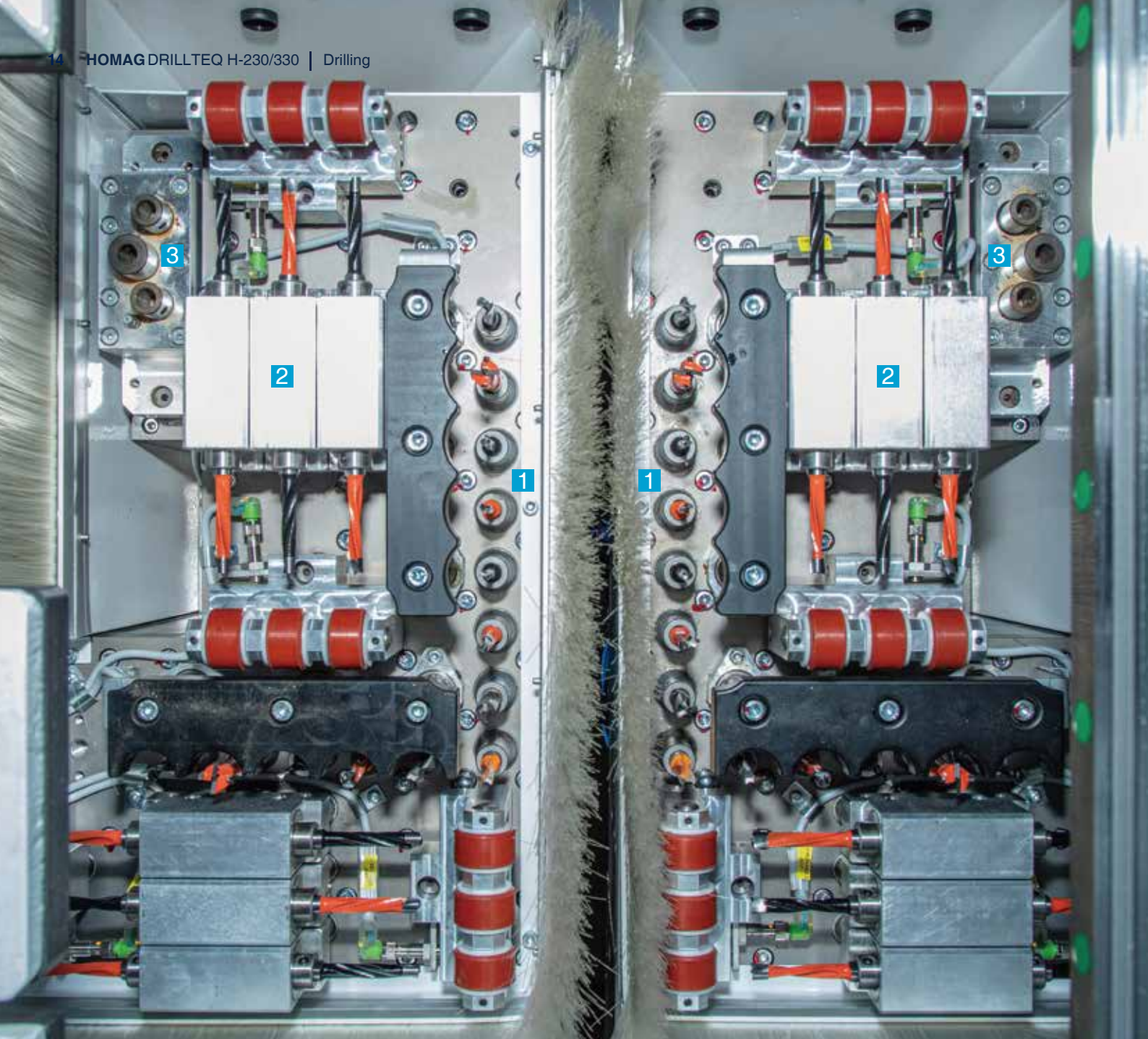

1 Upper vertical drilling spindles

4 Lower vertical drilling spindles

2 Horizontal drilling spindles

5 3,5 kW routers

3 Hinge Drill (optional)



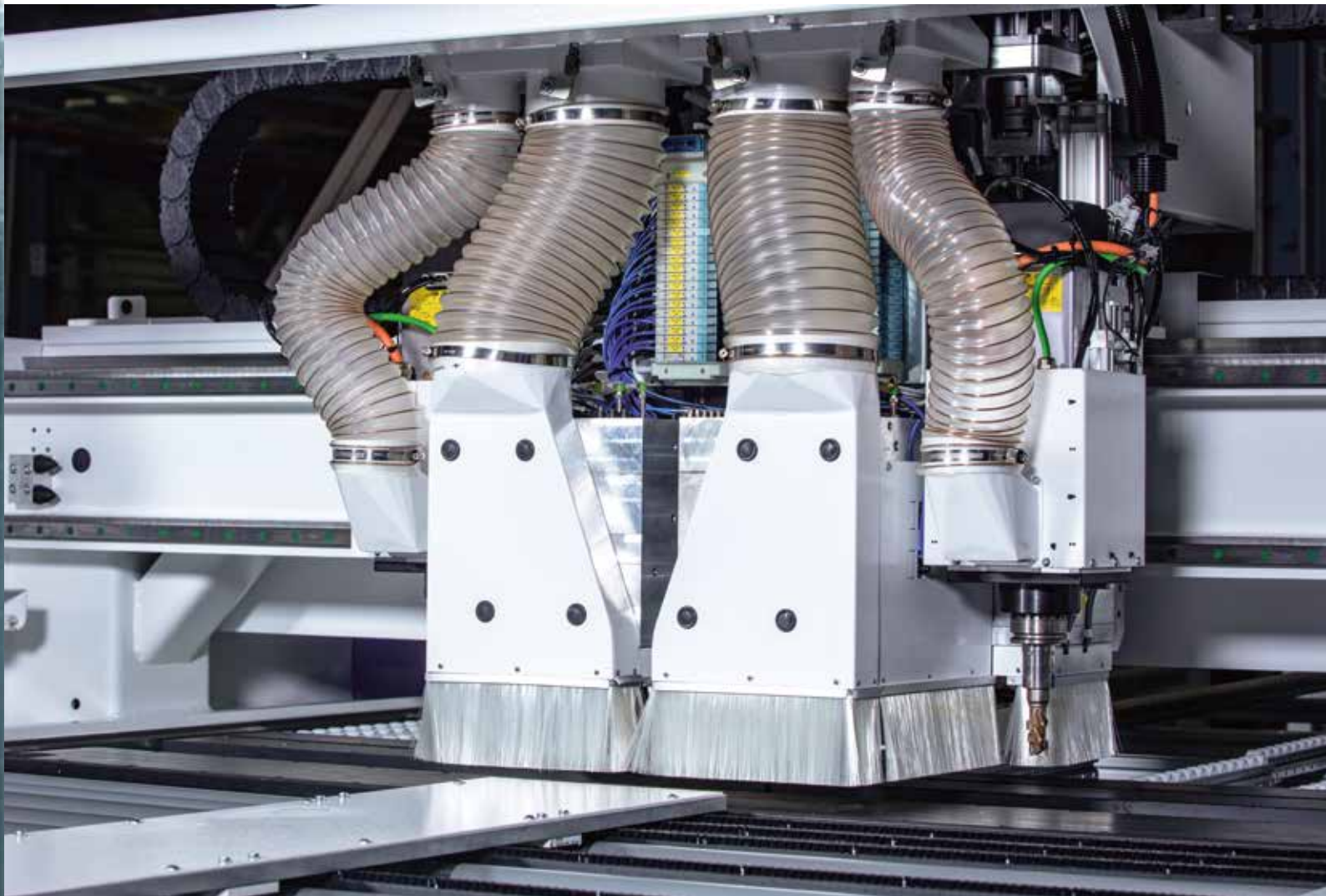

The drilling technology – Our experience is your added value

Long service life, low wear and maximum precision. The German drilling technology of the HOMAG Group is already included in the DRILLTEQ as standard. It ensures you the highest quality of workmanship in the long term, which does not lose any of its high quality even with thousands of drilling operations per year.

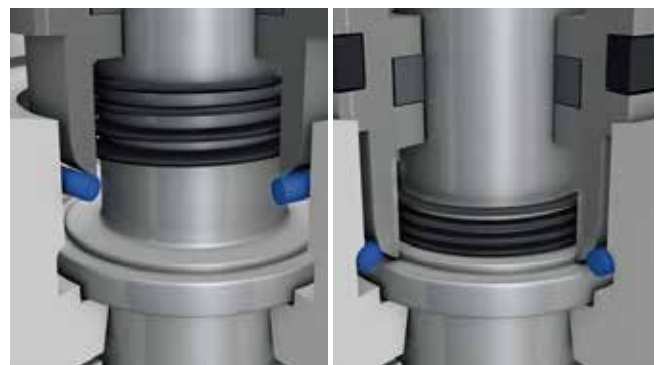

Automatic spindle clamping

- Always exactly the same drilling depth – irrespective
- Constant quality by high repeat accuracy

Perfectly matched to you – The right equipment for your needs

IN PERFECTION! The configuration variety of the drilling equipment provides all possibilities regarding your requirements.

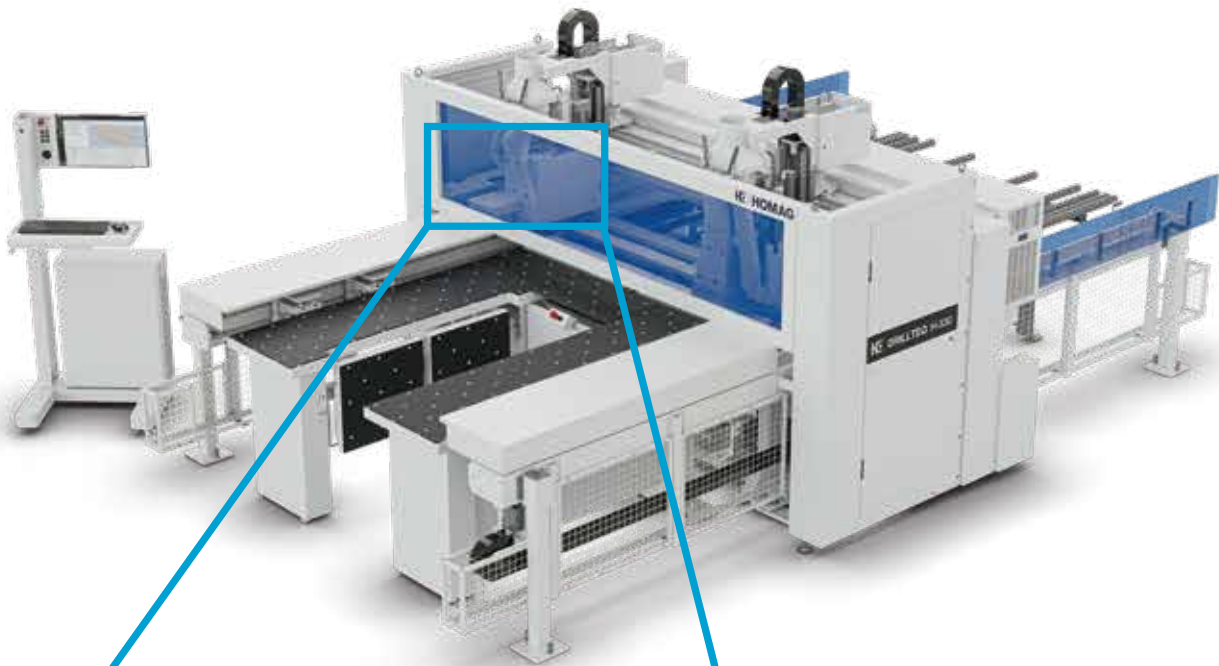

Optional equipment with automatic tool change system provides you with more processing possibilities.

Available for 6-side drilling series DRILLTEQ H-230/330.

Tool Change System

- Spindle with HSK F63
- 4-fold linear tool changer
- Optionally mounted at the side of machine
- Convenient and automatic exchange of tools from sides.
- Tool length control: tool length is queried and compared with the integrated tool database

HSK tool chuck – Holds securely what belongs together

HOMAG relies on the HSK interface between the tool and the work spindle. At this important position, the tool holder must be able to guarantee a tight fit, but also a quick tool change and precision in the manufacture of the workpiece. The HSK holder does this reliably.

Added value compared to ISO steep taper shank

The clamping force acting on the flange of an HSK shank is twice as high as on an ISO steep taper shank. An HSK shank is therefore much more resistant to pull-out forces. This means that a tool can be operated at higher speeds.

Thanks to the additional clamping force, the radial rigidity of HSK tool holders is up to five times higher than that of ISO tool holders.

Another HSK improvement over ISO steep taper shanks is the tool change capability. Due to the short length of the HSK taper and the lower weight of the hollow shank, tool changes can be carried out more quickly than with conventional tool holders.

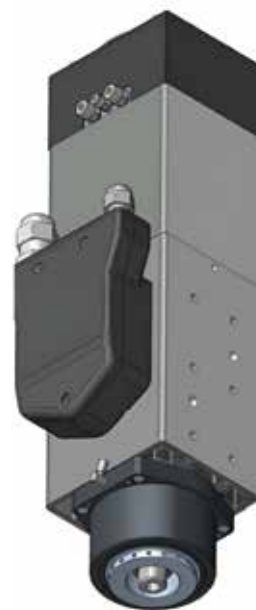
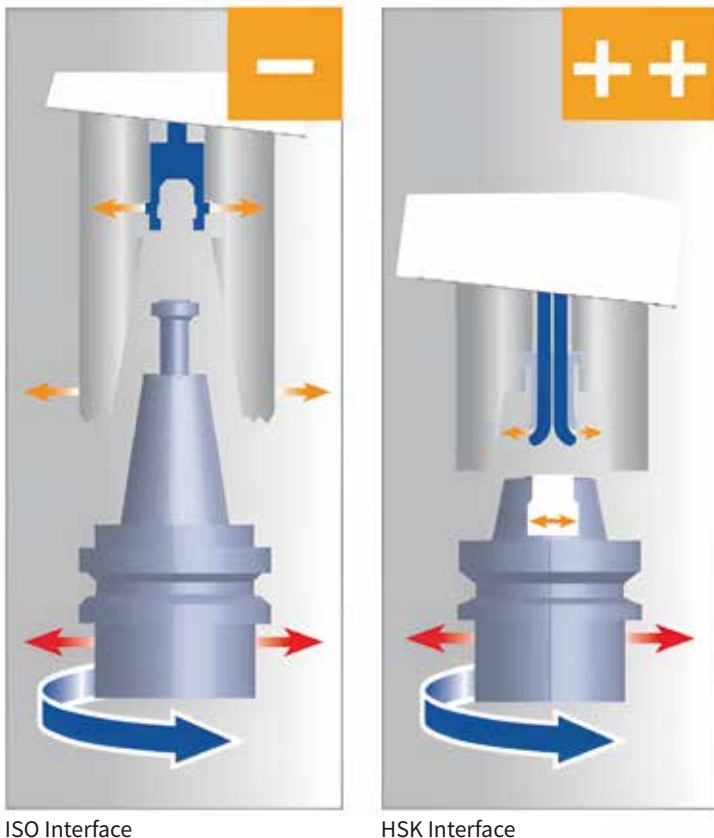

Advantages of HSK at a glance

- More resistant to bending loads
- Radial rigidity, deeper cuts and higher feed rates for milling and drilling operations, improving processing accuracy and surface quality
- Quick tool change thanks to short HSK taper and no retaining catch for clamping the shank

Safety first, because operator's safety is always important! Comprehensive safety concept

The DRILLTEQ H-230 and H-330 have a comprehensive safety concept. German standards make working with this equipment not only comfortable, but also safe to handle.



The clamps on both sides are fast moving.
The upper safety fence protects the processing area from the sides.



The lower safety fence prevents entry into the working area.

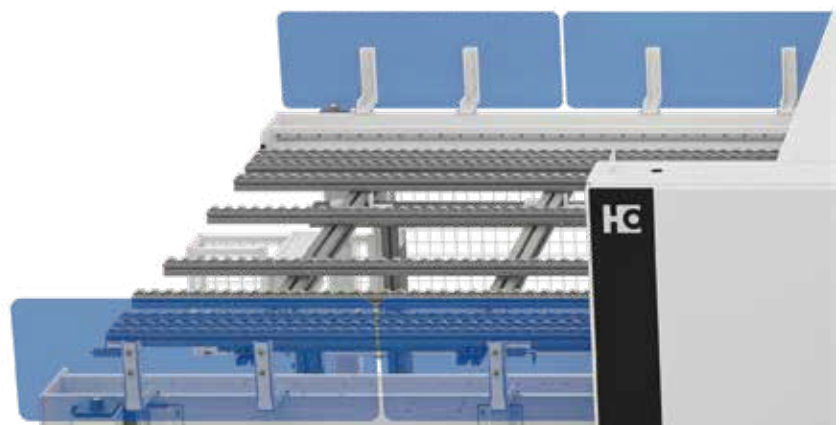

The Protective cover closed the processing area, to ensure the operator safety during the processing (avoid personal contact with machining tools and moving parts).

Connected cell concepts – All solutions for you

Each cell in particular is an ideal solution for efficient panel processing in furniture manufacturing.

With these cell concepts, we show how the value can be increased by an automatic connection with stand-alone machines. The systems make the production process more efficient and reliable through the machine network management by the intelligent HOMAG cell control.

All the standard concepts here presented can be easily integrated into your workshop.

Of course, in accordance with your actual demand to discover the most appropriate solution is also possible.

YOUR BENEFITS AT A GLANCE

- Cost reduction - reduction of personnel expenses
- High availability - Machine uptime can be extended to nearly 100%.
- Highly flexible production - fulfillment of drilling processing for all panel sides
- Low maintenance operation - 24/7 availability
- Consistent high quality - No reduction/change due to staff changes

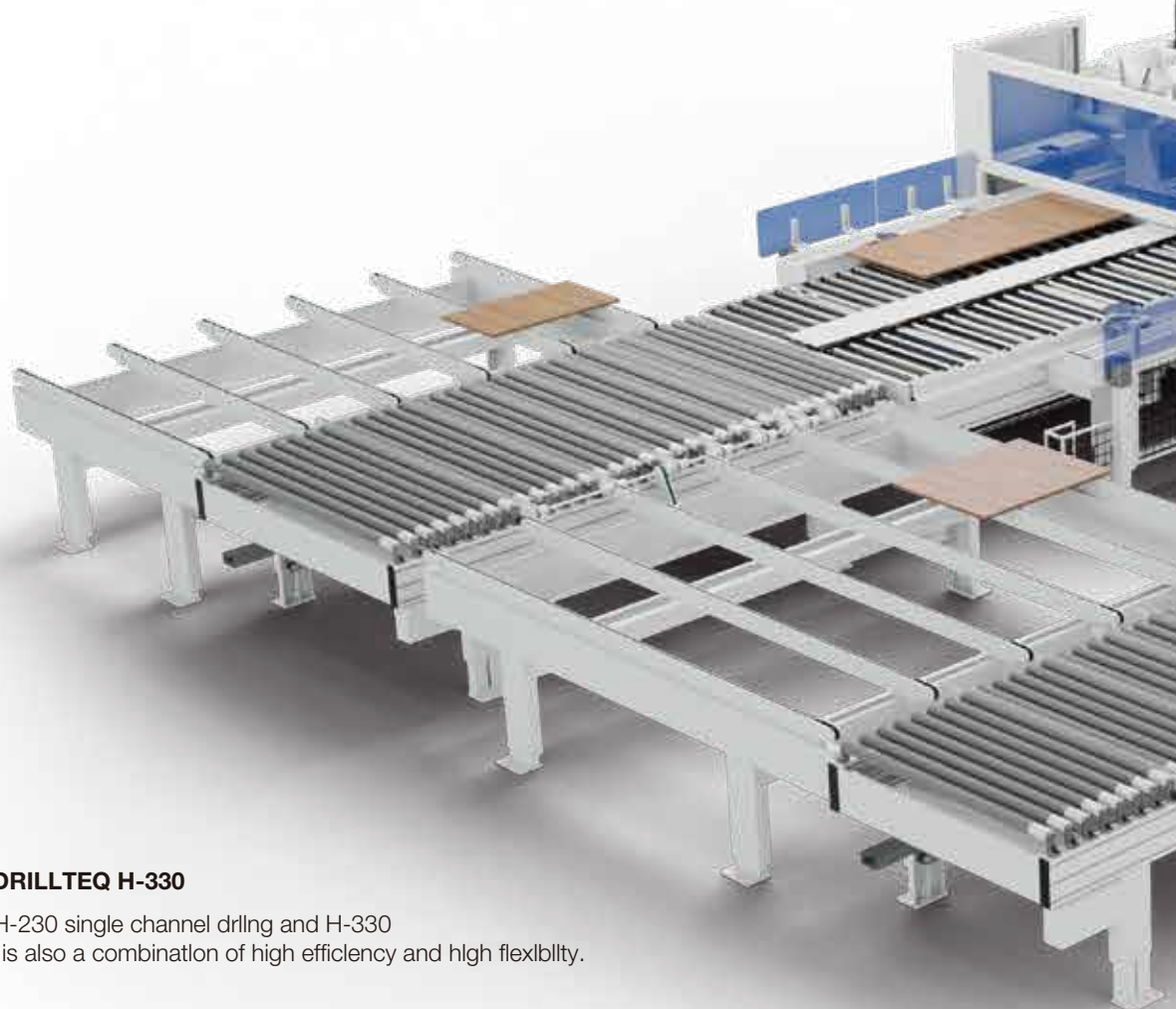

DRILLTEQ H-230 + DRILLTEQ H-330

A combination cell of H-230 single channel drilling and H-330 double channel drilling is also a combination of high efficiency and high flexibility.

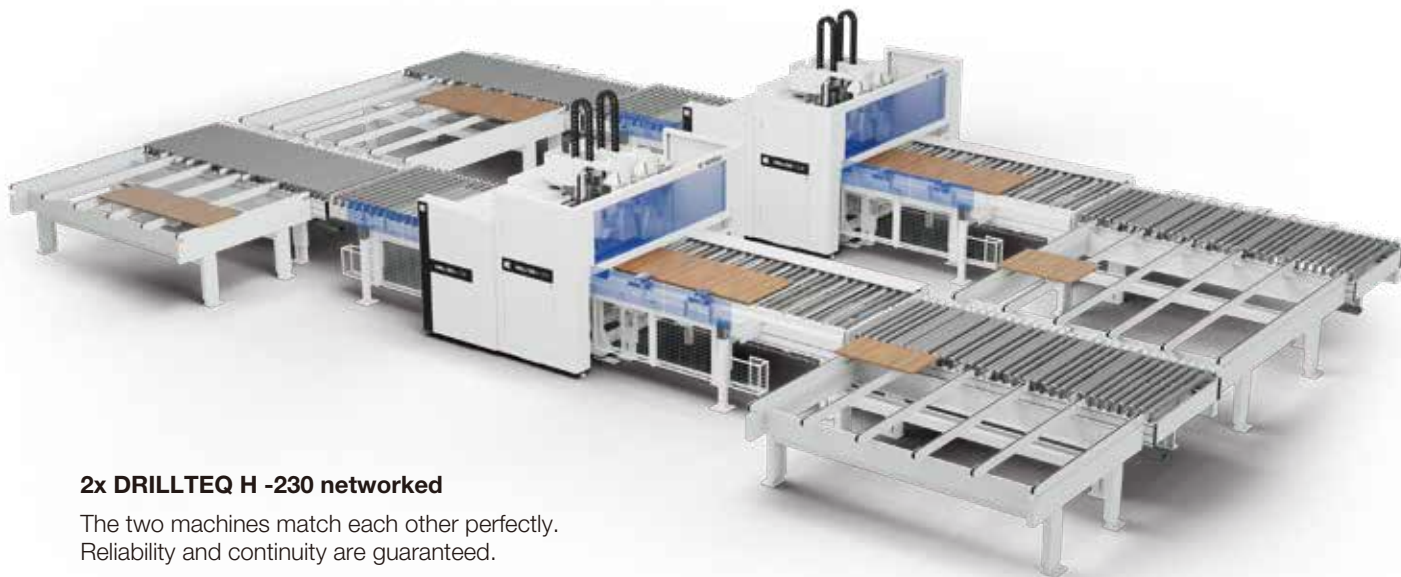

2x DRILLTEQ H -230 networked

The two machines match each other perfectly.
Reliability and continuity are guaranteed.

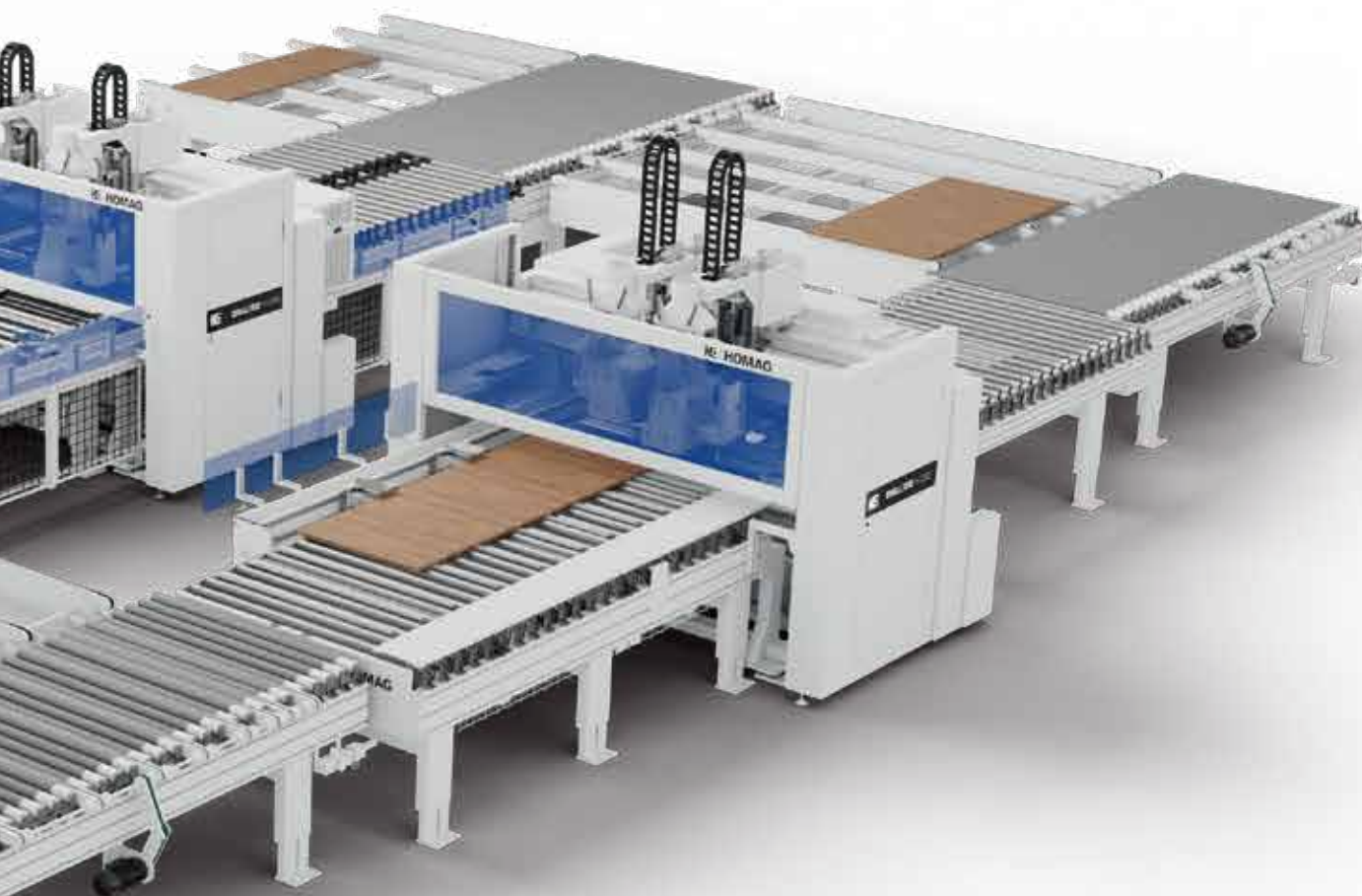

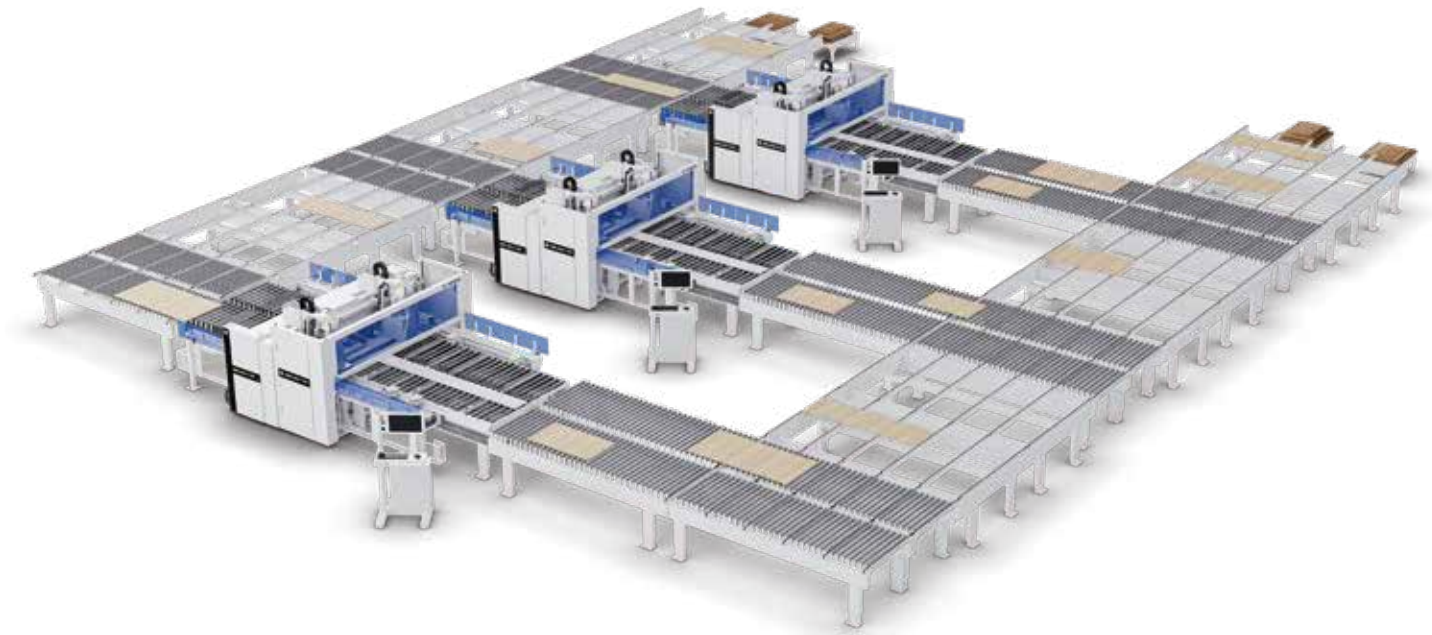

3x DRILLTEQ H -330 networked

The three machines match each other perfectly. Full process reliability and continuity is guaranteed.

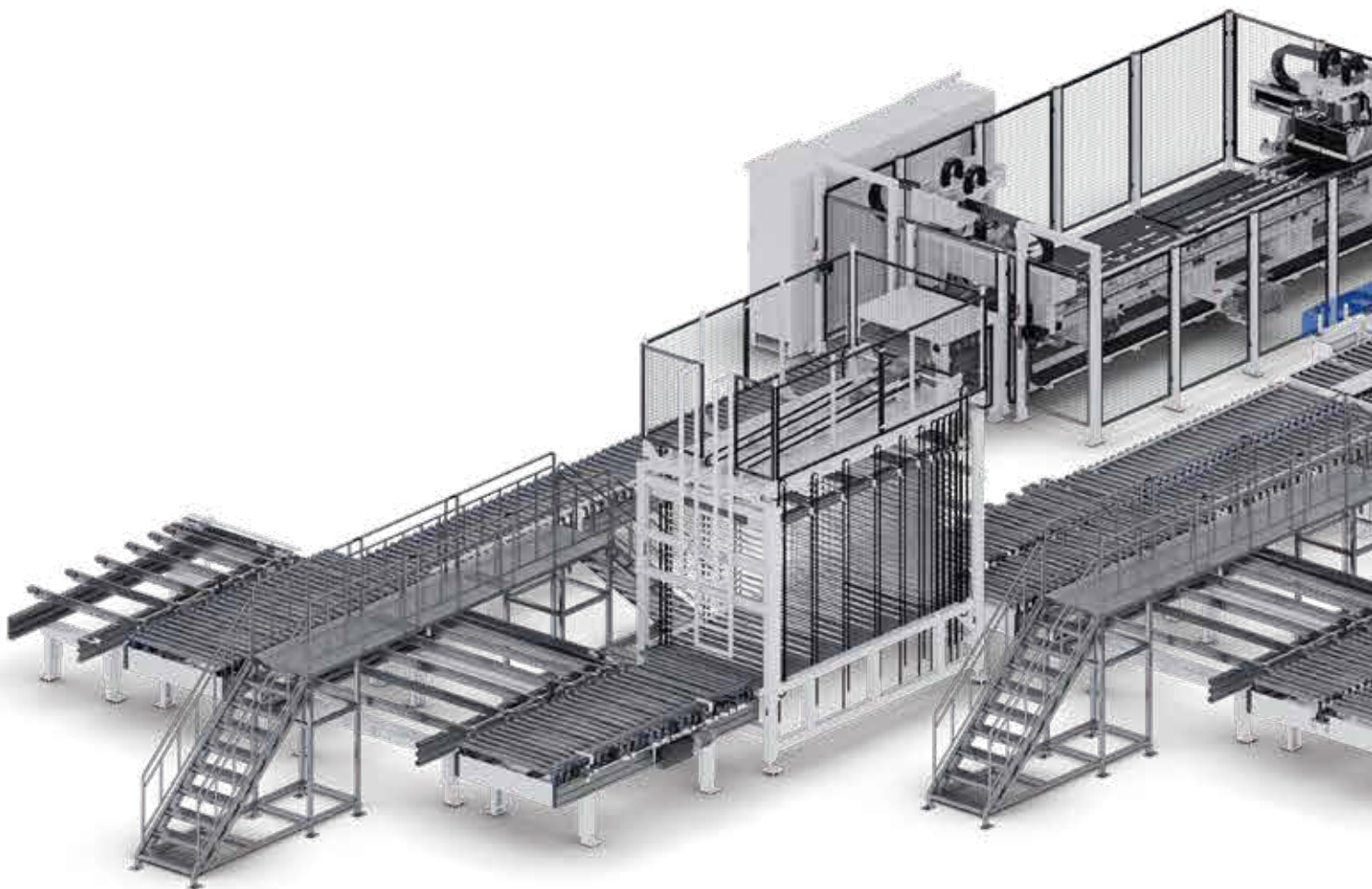

Connected cell concepts – All solutions for you

Each cell in particular is an ideal solution for efficient panel processing in furniture manufacturing.

With these cell concepts, we show how the value can be increased by an automatic connection with stand-alone machines. The systems make the production process more efficient and reliable through the machine network management by the intelligent HOMAG cell control.

All the standard concepts here presented can be easily integrated into your workshop.

Of course, in accordance with your actual demand to discover the most appropriate solution is also possible.

YOUR BENEFITS AT A GLANCE

- Cost reduction - reduction of personnel expenses
- High availability - Machine uptime can be extended to nearly 100%.
- Highly flexible production - fulfillment of drilling processing for all panel sides
- Low maintenance operation - 24/7 availability
- Consistent high quality - No reduction/change due to staff changes

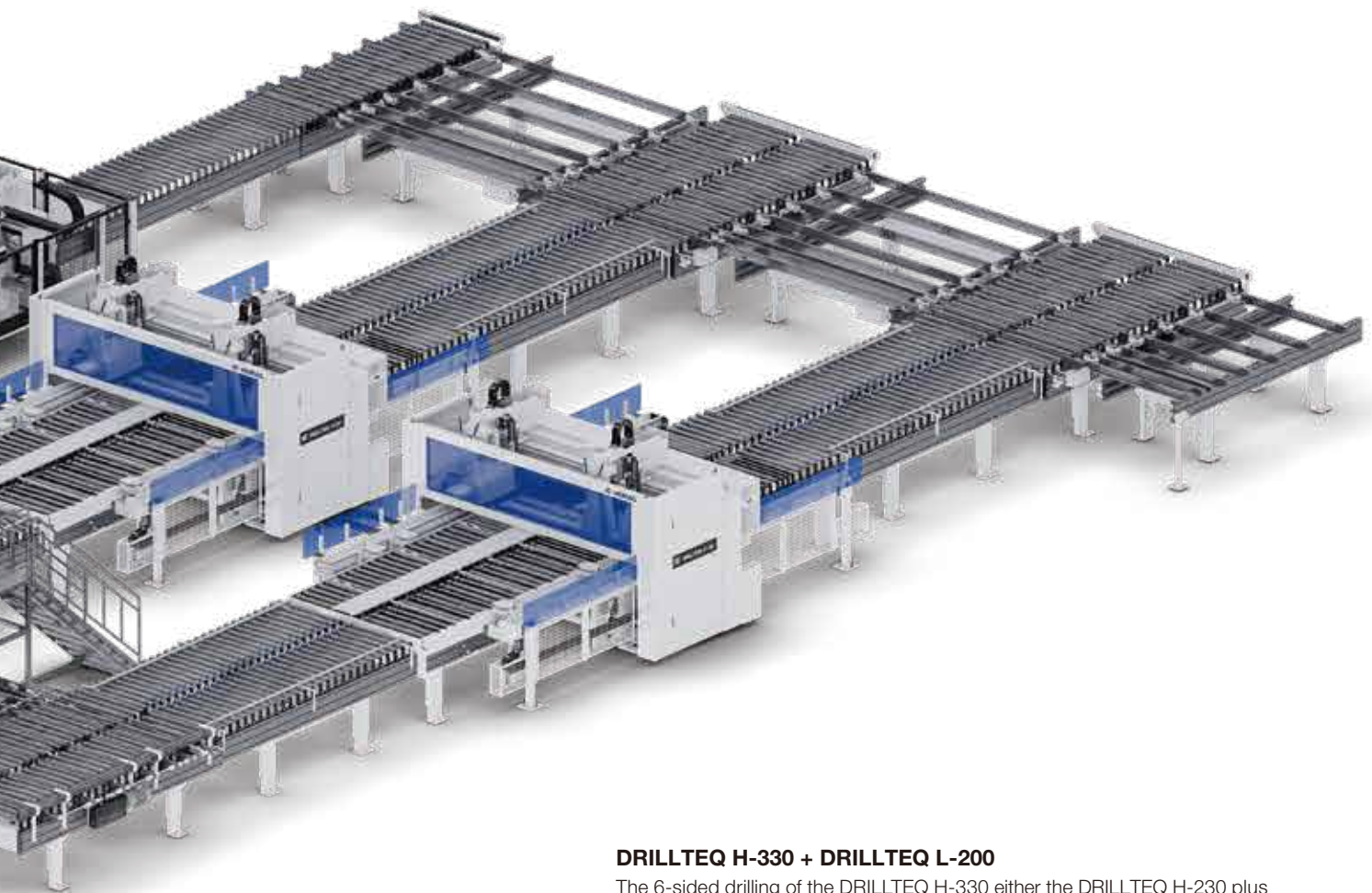

DRILLTEQ H-330 + DRILLTEQ L-200

The 6-sided drilling of the DRILLTEQ H-330 either the DRILLTEQ H-230 plus the 4-sided drilling of the DRILLTEQ L-200 is the perfect combination.

The high efficiency and the fully comprehensive processing of the workpieces perfectly complement these three machines in combination.

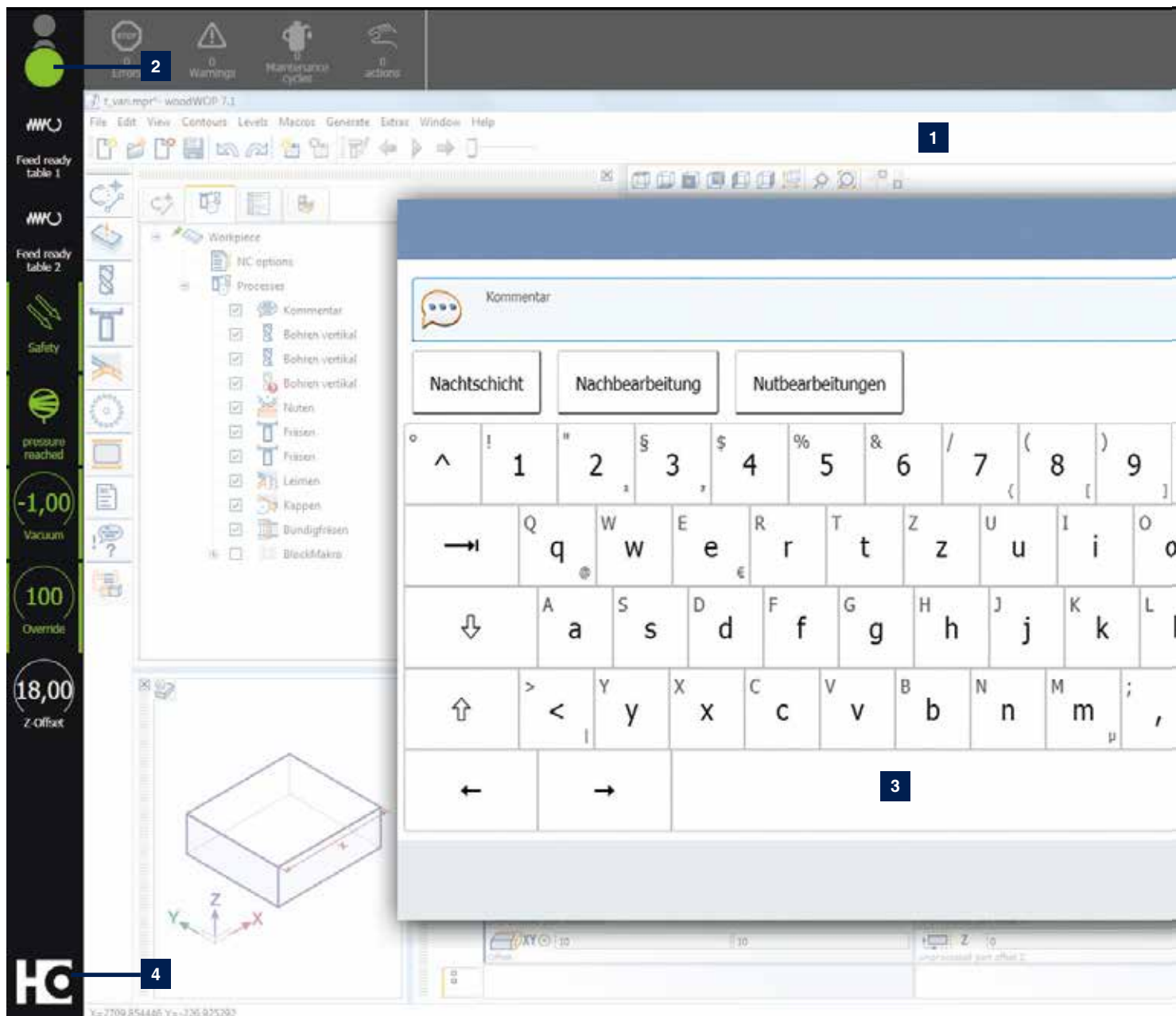

1 The powerTouch2 screen is clearly structured. You can see all the important information at a glance, but you still have all the details.

2 We have also improved the traffic light dialog further. You can now directly influence the machine's production readiness by selecting actions via the traffic light icon.

3 A functional pop-up keyboard that can be kept open, including automatic word completion for faster entries (when you enter the first letters, frequently used applications are proposed and you can select them directly).

4 Enhanced "Start" menu with additional information displayed (e.g. an indication of how many messages are currently pending or status bars that show the progress of the application) and direct access to actions (e.g. confirmation of actions without having to jump to the application).

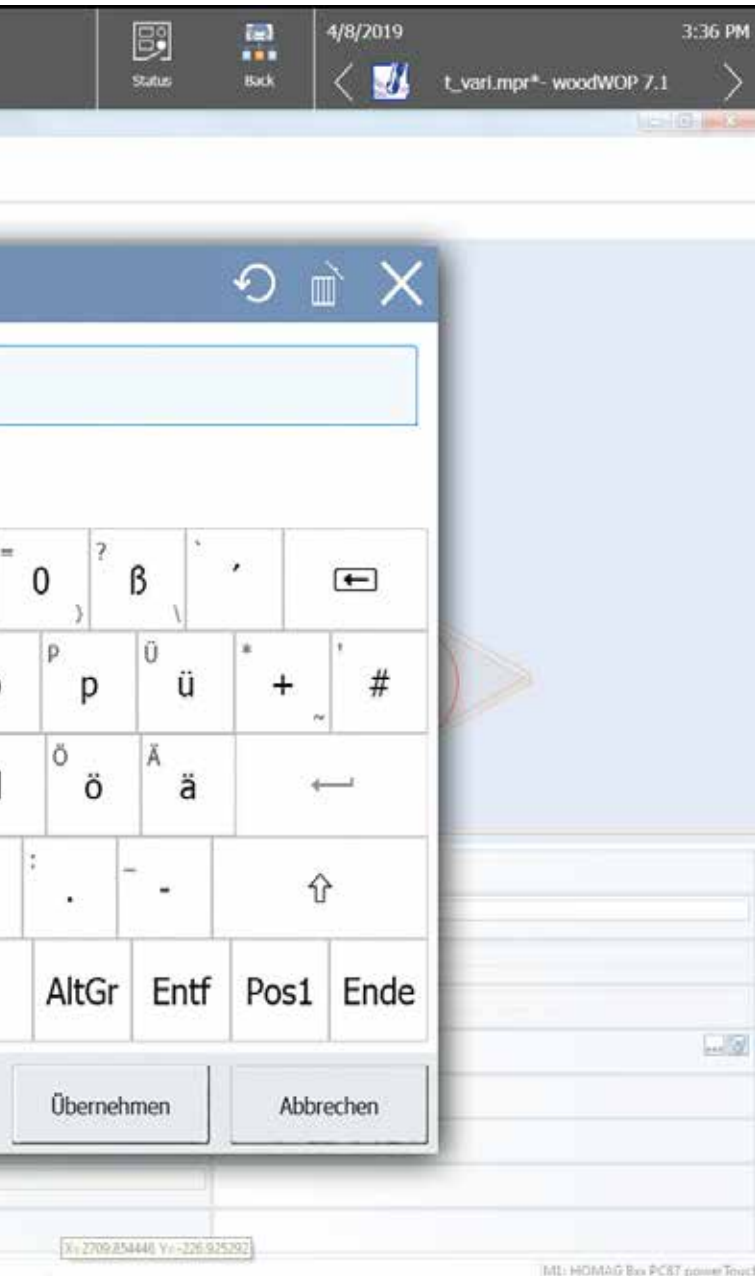

The next generation of powerTouch: **powerTouch2**

Faster, more comfortable, clearer: Enjoy the benefits of our further improved powerTouch user interface. We have optimized our standardized operating concept and further adapted it to our customers' requirements. Controlling your HOMAG machines is now even faster and more intuitive. The new, modern design has a clear structure. The innovative touch operation allows you to achieve the desired result easily and comfortably.

With the new powerTouch generation, you can enter information at your machine even more quickly. Compared to the previous version, you can achieve a time saving of up to 30%. This is possible thanks to new features, such as automatic word completion, a pop-up keyboard that can be kept open and Windows-like functions, such as the selection of common actions directly via the start button.

Our successful powerTouch philosophy – **standardized, simple, ergonomic, evolutionary** – consistently further developed



THE HIGHLIGHTS AT A GLANCE:

- Direct and efficient operation, up to 30% faster
- Clearer and more informative thanks to additional information and live illustrations instead of program icons
- New applications for operating and controlling machines and systems (e.g. NCCenter in the PC87 control system on CNC machines or woodCommander 4 on throughfeed machines)
- Fresh, attractive design, based on the new HOMAG machine design

All inclusive – Software

WITH THIS SOFTWARE PACKAGE YOU ARE »READY TO RACE«. You will receive one of the most established CNC-programming systems, the woodWOP software, which has proven itself by more than 30.000 installations worldwide.

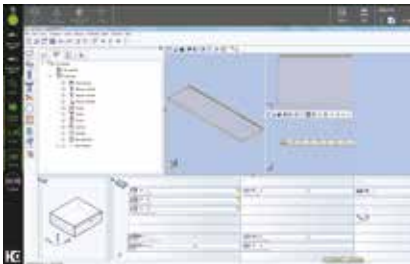

woodWOP | License Machine

- Fast and intuitive operation thanks to simple, direct navigation
- Quickly create individual subprograms
- Increased programming security through 3D images of workpieces, processing and clamping equipment



PulseCloud ready

Do you need support with Dashboard, Machine management, Tool management or Simple preventive maintenance? We know it and are at your side. MMR Basic provides a direct connection to the PulseCloud. Data is provided at a glance. Your fast support is guaranteed.

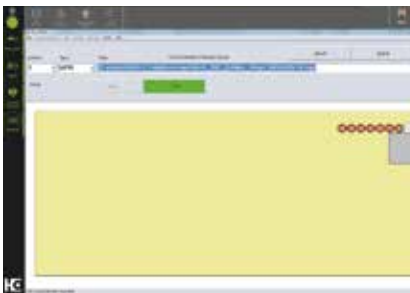

Slot assignment

- Simple control of main machine functions through soft keys
- Graphical configuration
- Automatic mirroring of workpieces



woodWOP DXF Basic

- Interface for CAD-Data Import
- Basis to generate woodWOP programs



Machine data acquisition MMR Basic

- Record quantities and actual operating times on the machine
- Integrated maintenance instructions for optimum time and quantity-based planning, as well as performing maintenance



HOMAG China - Your local contact



Office building

The HOMAG Group has been active in China for over 40 years and can therefore look back on a great deal of experience in the world's largest furniture market. A nationwide organization with over 700 employees including engineering, production, sales and service is spread over five regional branches. Short distances to our customers ensure efficiency and sustainability.

In addition to machines, the HOMAG Group offers complete solutions with software and digital tools. The goal is to support our customers and the Chinese market on their way to a smart value chain in terms of quality, automation, end-to-end processes and the latest technologies.



Assembly line



Good structured order transaction

HC LIFE CYCLE SERVICES

The sale of our machines comes with all-in optimum service backup and individual advice. We support you with service innovations and products which are especially tailored to your requirements. With short response times and fast

customer solutions we guarantee consistently high availability and economical production – over the entire life cycle of your machine.



REMOTE SERVICE

- Hotline support via remote diagnosis by our trained experts regarding control, mechanics and process technology. Thus, more than 90% less on-site service required and consequently a faster solution for you!
- The ServiceBoard App helps to solve tasks in a fast, simple and concrete way. This is achieved by mobile live video diagnosis, automatic sending of service requests or the online spare parts catalog eParts.



SPARE PARTS SERVICE

- High spare parts availability and fast delivery.
- Ensuring quality by predefined spare parts and wear parts kits, comprising original spare parts.
- Identify and inquire for spare parts online under www.eParts.de 24/7, or buy even faster and more comfortably in the new HOMAG Webshop eCommerce.



MODERNIZATION

- Keep your machinery up to date and increase your productivity as well as your product quality. This is how you can meet tomorrow's requirements today!
- We support you with upgrades, modernization as well as individual consultancy and developments.



DIGITAL SERVICES

- ISN (intelliServiceNet) – The new remote service solution of the future! Fast restart of production because the remote service employee has extensive access to relevant physical data.
- intelliAdvice App – provides help for self-help. The preventive solutions proposed in the new App are the combination of our experiences and existing machine data.

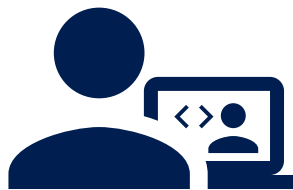

SOFTWARE

- Telephone support and consultancy through software support.
- Digitalization of your sample parts via 3D scanning saves time and money compared to new programming.
- Subsequent networking of your machinery with intelligent software solutions ranging from construction to production.



FIELD SERVICE

- Increased machine availability and product quality by certified service staff.
- Regular checks through maintenance / inspection guarantee the highest quality of your products.
- We offer you the highest availability of technicians in order to reduce downtimes in case of unpredictable troubles.

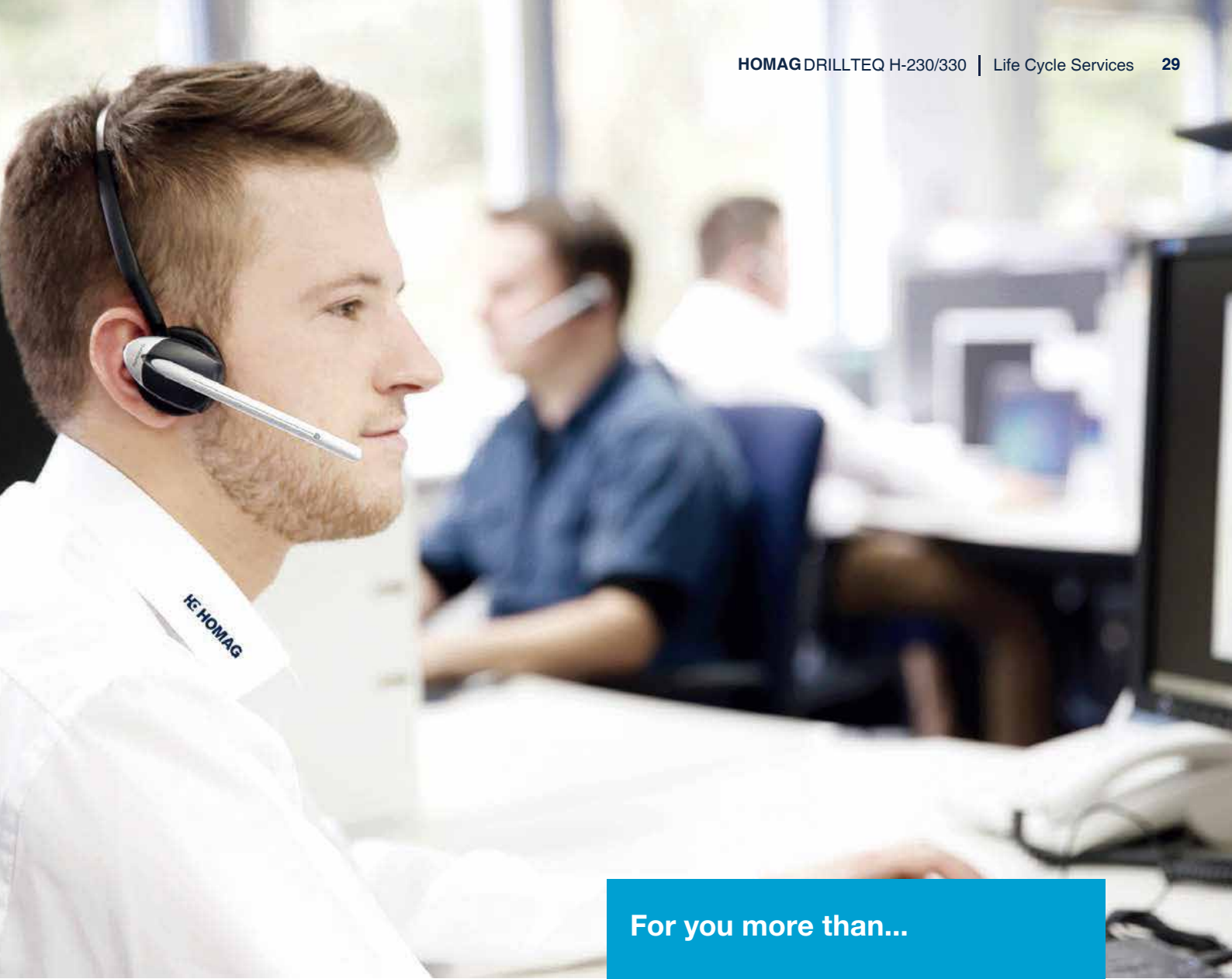

For you more than...

1,350

service employees worldwide

90 %

less on-site service thanks to successful remote diagnosis

5,000

customer training sessions per / year

150,000

machines, all electronically documented in 28 different languages – in eParts

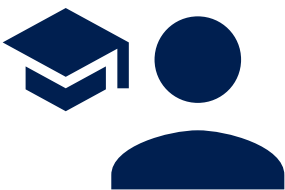

TRAINING

- Thanks to training perfectly suited to your requirements, your machine operators can optimally operate and maintain the HOMAG machines.
- The training also include customer-specific training documents with exercises proven in practice.
- Online training and webinars. Learn without traveling, meet your trainer in the digital classroom.

DRILLTEQ H-230

TECHNICAL DATA			
Footprint			
L	mm	5,900 / 7,300	
W	mm	3,100	
H	mm	2,550	
Workpiece dimension			
Length	mm	250 - 3000	
Width (800)	mm	60 (40) - 800	
Width (1250)	mm	60 (40) - 1,250	
Hight	mm	8 - 40	
Drilling Head TOP			
vertical spindles	Qty	13 or 2 x 13	
vertical spindle clamping		Yes	
horizontal spindles in X+/X-	Qty	3X+/3X- or 2 x (3X+/3X-)	
horizontal spindles in Y+/Y-	Qty	3Y+/3Y- or 2 x (3Y+/3Y-)	
Frequency controlled	RPM	1,250 - 7,500	
Drilling Head Bottom 1 & 2			
vertical spindles	Qty	8	
vertical spindle clamping		Yes	
Frequency controlled	RPM	1,250 - 7,500	
Dust extraction			
Diameter	mm	4 x 160	
Electric			
max. connection load	KW	22	
Air			
Compressed Air	bar	7	
Machine			
approx. weight	KG	5,500	

OPTIONS			
Router			
Frequency controlled	RPM	18,000	
Power	KW	3.5	
Collet	Type	ER25	
Spindle for auto tool change			
Frequency controlled	RPM	24,000	
Power	KW	4.5	
Collet	Type	HSK-F63	
Tool changer			
Type		Linear	
Fold	Qty	4	
Max. tool weight	Kg	5	
Infeed			
Type		Air-cushion table	
Type		Self-aligning roller conveyor	
Outfeed			
Type		Support table	
Type		Cross belt	
Type		Driving roller conveyor	

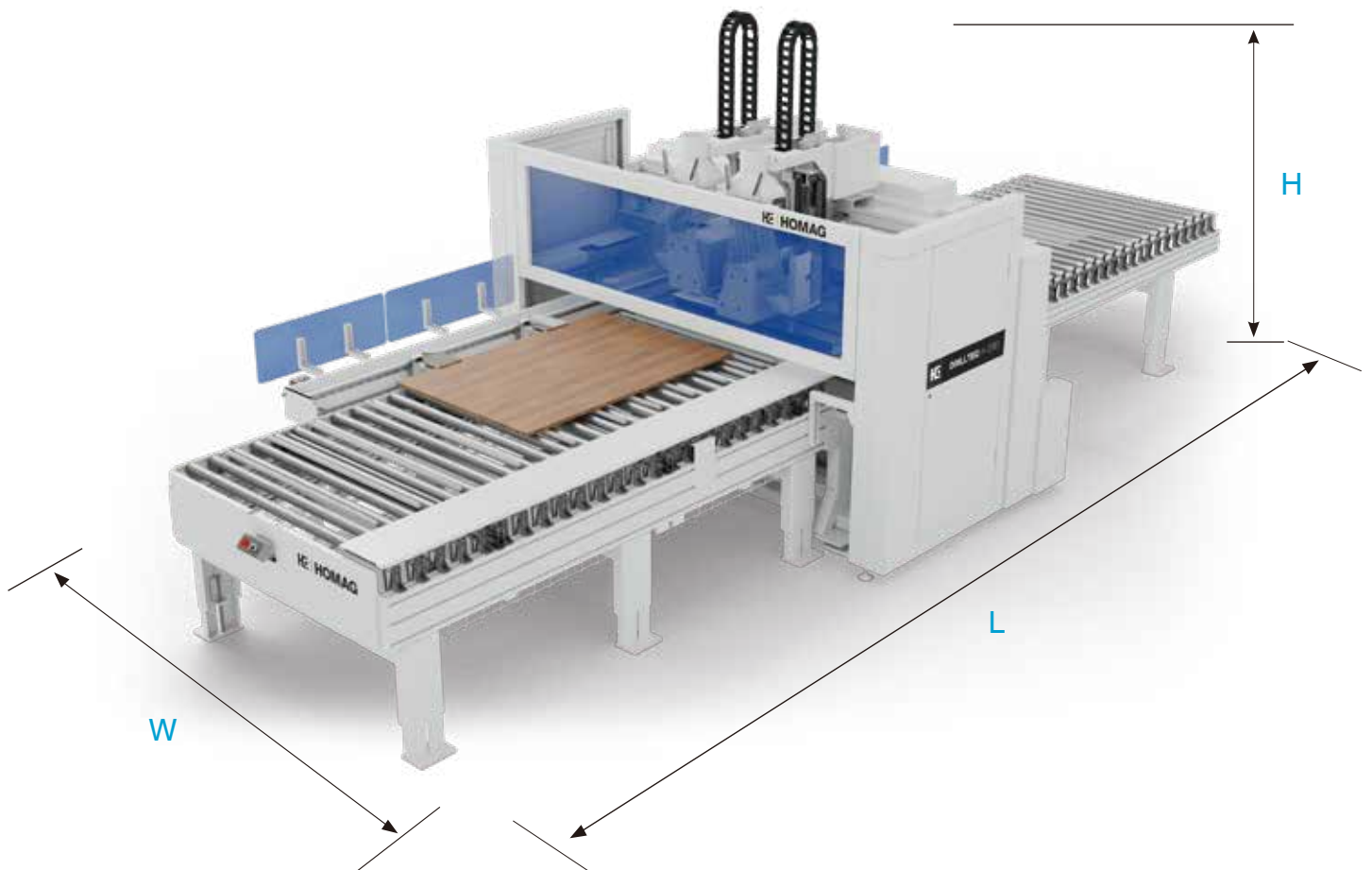

DRILLTEQ H-330

TECHNICAL DATA		
Footprint		
L	mm	6,000 / 7,200
W	mm	3,600
H	mm	2,550
Workpiece dimension		
Length	mm	250 - 3000
Width (single part)	mm	60 (40) - 1,250
Width (double parts)	mm	2 x 620
Height	mm	8 - 40
Drilling Head TOP 1 & 2		
vertical spindles	Qty	2 x 13
vertical spindle clamping		Yes
horizontal spindles in X+/X-	Qty	2 x (3X+/3X-)
horizontal spindles in Y+/Y-	Qty	2 x (3Y+/3Y-)
Frequency controlled	RPM	1,250 - 7,500
Drilling Head Bottom 1 & 2		
vertical spindles	Qty	2 x 8
vertical spindle clamping		Yes
Frequency controlled	RPM	1,250 - 7,500
Dust extraction		
Diameter	mm	3 x 160
Electric		
max. connection load	KW	26
Air		
Compressed Air	bar	7
Machine		
approx. weight	KG	8,800

OPTIONS		
Router		
Frequency controlled	RPM	18,000
Power	KW	3.5
Collet	Type	ER25
Spindle for auto tool change		
Frequency controlled	RPM	24,000
Power	KW	4.5
Collet	Type	HSK-F63
Tool changer		
Type		Linear
Fold	Qty	4
Max. tool weight	Kg	5
Infeed		
Type		Air-cushion table
Type		Self-aligning roller conveyor
Outfeed		
Type		Support table
Type		Driving roller conveyor

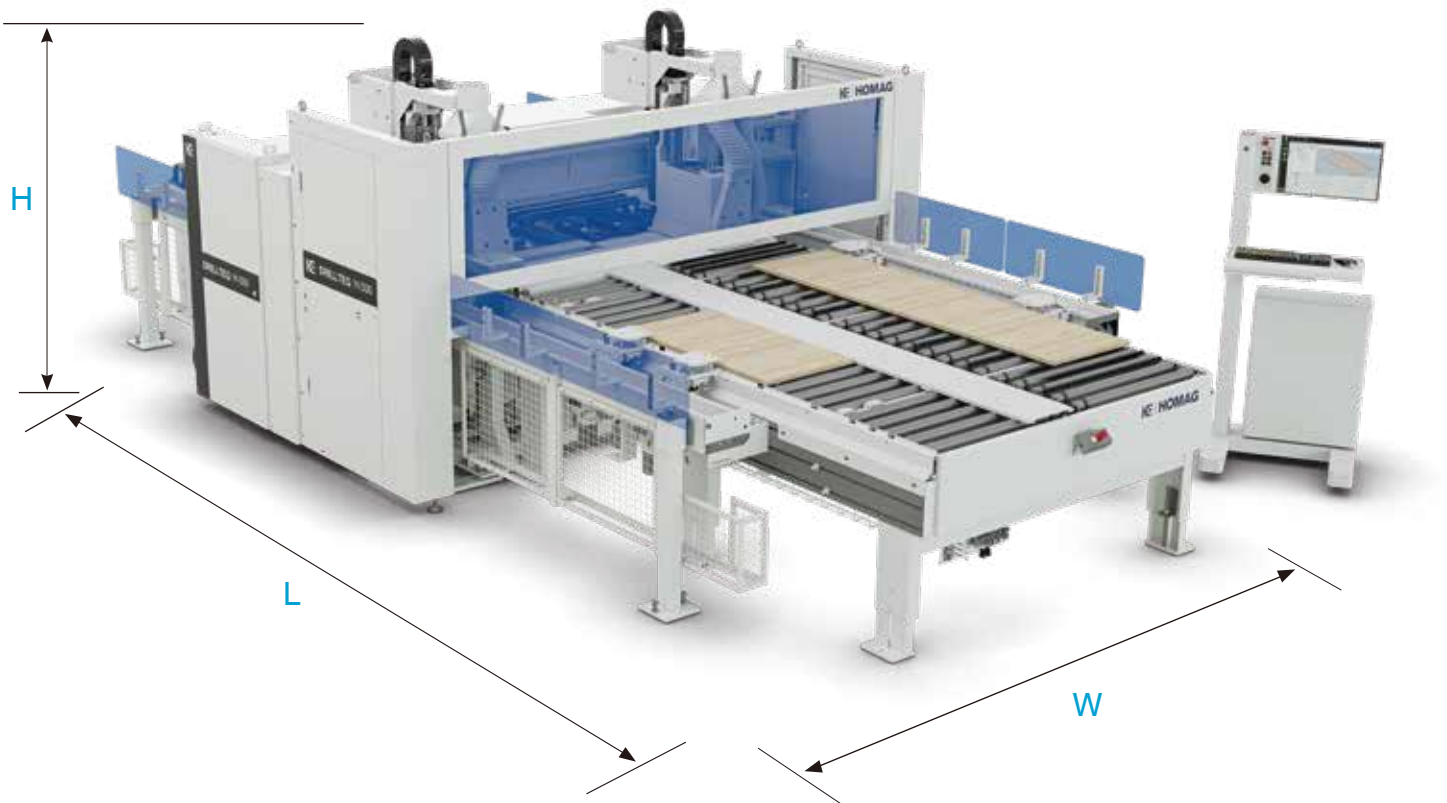



HOMAG Group AG
marketing-chn@homag.com
www.homag.com

YOUR SOLUTION